

**UNIBODY LITTROW DIODE LASER
(Short Cavity)**

Part List

Tobias Brown-Heft, Eryn Cook, Paul Martin

09/13/2011

Summary of parts:

Part Name	Material	Starting Dimensions	Quantity Per Laser
Baseplate	6061-T6 Aluminum	4.5" x 7.75" x 1"	1
Bottom Cover	6061-T6 Aluminum	4.48" x 6" x 0.75"	1
Cavity	6061-T6 Aluminum	4.83" x 6" x 1"	1
Top Cover	6061-T6 Aluminum	4.48" x 6" x 0.75"	1
Diode Collimation Tube Mount	6061-T6 Aluminum	1.40" x 0.78" x 1.08"	1
Optical Isolator Mount (Large Version)	6061-T6 Aluminum	1.75" x 2.05" x 1.60"	1
Optical Isolator Mount (Small Version)	6061-T6 Aluminum	1.75" x 2.05" x 0.375"	1
Diode Protection Circuit	PC Board	1" x 1"	1
Brewster Window	Microscope Slide	0.7" x 0.7"	1

**UNIBODY LITTROW DIODE LASER
(Short Cavity)**

Additional Components

Tobias Brown-Heft, Eryn Cook, Paul Martin

09/13/2011

Summary of parts:

<u>Description</u>	<u>Company</u>	<u>Part Number</u>	<u>Quantity per Laser</u>	<u>Unit Cost \$</u>
15 Pin D-sub Connector (male)	Amphenol	DSub-15	1	3.04
23AWG Heavy-build Polyimide Wire	MWS Wire Industries	23HML	~15 ft	0.0516/ft
Collimation Tube	Thorlabs	LT230P-B	1	111.00
Thermistor	EPCOS	B57861S0503F040	1	2.14
Temperature Sensor	Analog Devices Inc.	AD590	1	7.98
Piezomechanical Actuator	Noliac	SCMAP02	1	227.15
Sapphire Window	Swiss Jewel	W7.87	2	5.20
Thermoelectric Cooler	Laird	56460-501	3	16.73
Laser Diode	Sacher	G2 Series	1	1600.00
Holographic Diffraction Grating	Newport	6x12x3.2mm	1	16.73
Anamorphic Prisms	Thorlabs	PS871-B	2	143.20
Viton O-Ring (Dampening)	McMaster-Carr	AS568A-004	1	4.22
Viton O-Ring (Vacuum)	McMaster-Carr	AS568A-157	2	3.68
PM fiber coupler for (λ) with angle FC receptacle, f=7.5mm aspheric lens, and laser head adapter #15	Oz Optics	HPUC-23A-(λ)-P-7.5AS-15	1	230.95
¼" Aluminum Seal-Off Valve	DLH Industries	V1021-1	1	11.30
¼" Valve Operator, 25mm ISO Flange	DLH Industries	V1025-3-25	N/A	188.00
Optical Isolator ('Aspirin' Version)	Thorlabs	IO-D Series	1	465.00
Optical Isolator (Large Version)	Thorlabs	IO-3D Series	1	1575.00
3-Pin Connector for Diode Laser	Thorlabs	S8060	1	6.00

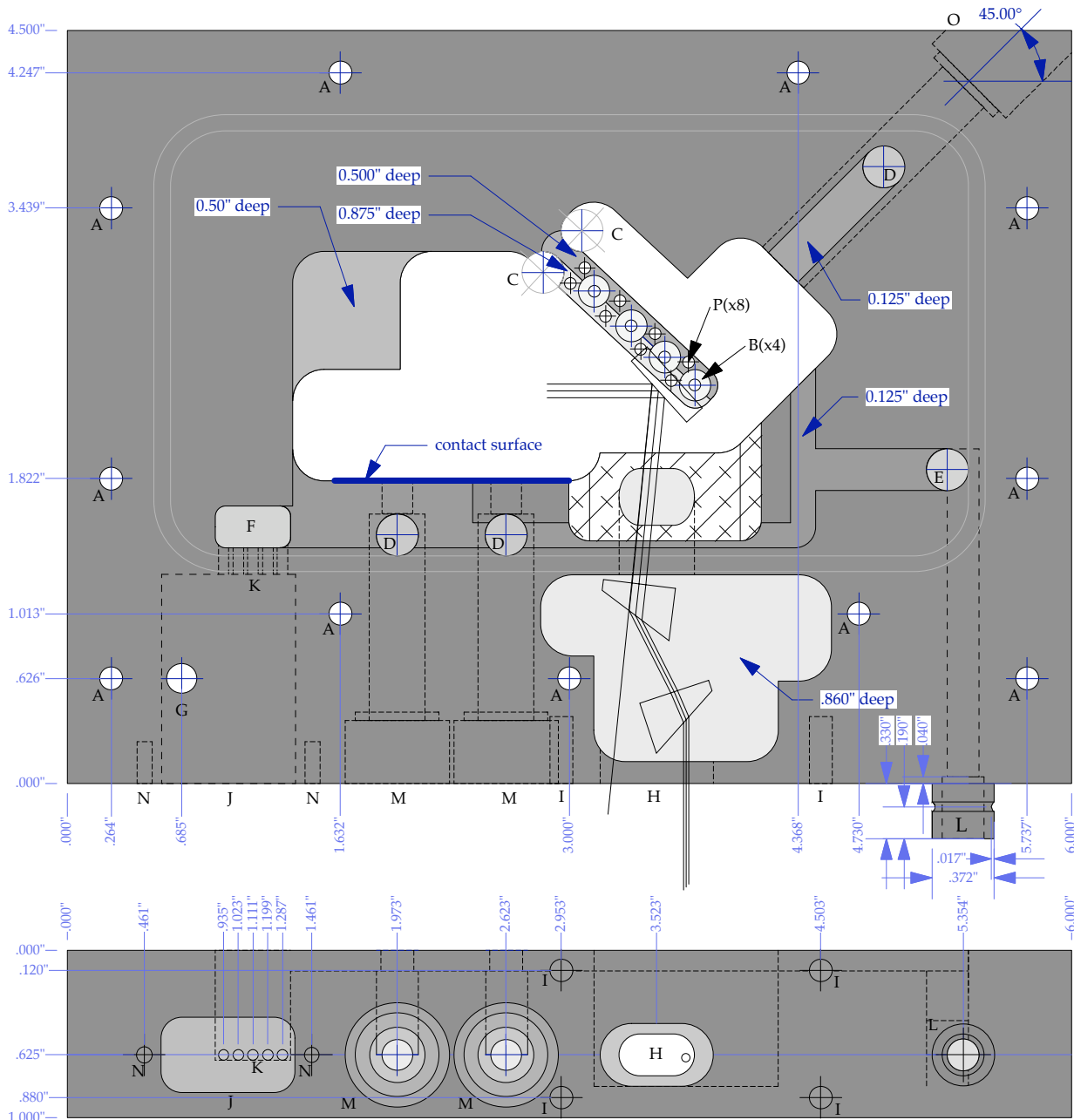

- NOTES:**
- A. 8-32 tapped, threads on both sides. Drill hole through part, and tap through, or tap at least 0.375" usable thread on each side. (x11)
 - B. 2-56 clearance through with counterbore to 0.970" deep (leaving 0.030" of material to bottom of part). (x4)
 - C. Plunge holes \varnothing 0.250" at these locations first, before cutting out inner cavity. See additional note 3.
 - D. Hole \varnothing 0.250", 0.625" deep. Details of bottom not important. (x3)
 - E. Hole \varnothing 0.250", 0.809" deep. Details of bottom not important.
 - F. Rectangular cavity 0.450" x 0.250" x 0.655" deep (through holes J), corner fillets \varnothing 0.125".
 - G. Hole \varnothing 0.177" through part.
 - H. 0.450" x 0.250" rectangular slot (with \varnothing 0.250" fillets) through to main cavity (2" deep). In addition, 0.675" x 0.375" rectangular slot (with \varnothing 0.375" fillets) through to prism pocket (0.25" deep).
 - I. 8-32 tapped, 0.400" deep. Details of bottom not important.
 - J. Rectangular cavity 0.800" x 0.450" x 1.250" deep, corner fillets \varnothing 0.250".
 - K. Holes \varnothing 0.063" through to cavity F (1.43" deep). Predrill 1.25" deep so bit won't wander. These holes should be made before cavity J is cut. (x5)
 - L. Drill hole \varnothing 0.190", 2.0" deep; details of bottom not important. Then ream \varnothing 0.250", 0.040" deep, flat bottom. External feature is a 0.33" tall, \varnothing 0.372" cylinder which has a channel cut using a 1/32" radius milling cutter. This channel is centered 0.190" from end of feature and has a depth of 0.017".
 - M. Drill hole for 8-32 loose (\varnothing 0.185") clearance through to inner cavity. Then counterbore to \varnothing 0.332", 1.610" deep, flat bottom. Then counterbore \varnothing 0.500", 0.425" deep relief with flat bottom, and \varnothing 0.625", 0.375" deep counterbore. Tap hole 3/8-24 so usable threads extend to at least 1" below outermost surface of part. (x2)
 - N. 4-40 tapped, at least 0.25" usable thread. Details of bottom not important(x2)
 - O. Hole angled 45° with respect to back surface, centered on hole D, and 0.688" below top of piece. All depths measured from top right corner. First drill through to main cavity \varnothing 0.345 ± 0.001". Then counterbore \varnothing 0.500", 0.696" deep relief with flat bottom and \varnothing 0.625", 0.647" deep counterbore. Tap as in M.
 - P. \varnothing 0.070" hole through part. (Cut after arm has been machined to 0.5" thick.) (x8)

UNIBODY LITTROW LASER -- MAIN CAVITY

E. COOK, P. MARTIN, D. STECK 3/24/11

- ADDITIONAL NOTES:**
1. Material is 6061-T6 aluminum. Starting block is 4.83" x 6" x 1".
 2. Standard tolerance is 0.005" unless otherwise noted.
 3. Cut holes A and B first. Secure part to supporting base using holes A (to support part) and holes B (to support arm), then cut main cavity through part, plunging first at locations C.
 4. Surfaces marked "contact surface" must be made very flat (finishing pass with end mill, as little chatter as possible).
 5. See attached drawing for selected details (ramp and arm).

RAMP DETAIL

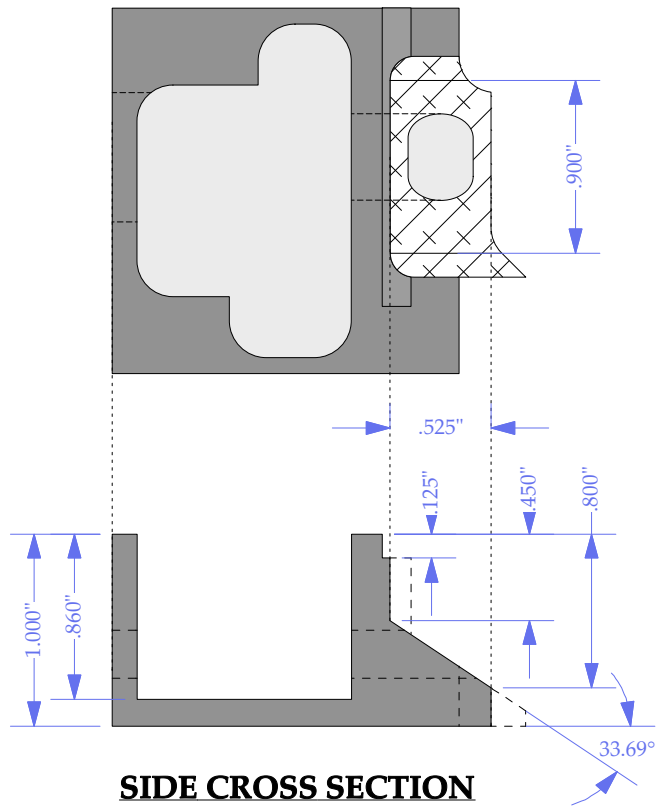

33.69 degree angle cut made using $\varnothing 0.25$ " end mill from above. Use many repeated CNC passes to make ramp as smooth as possible.

ARM DETAIL

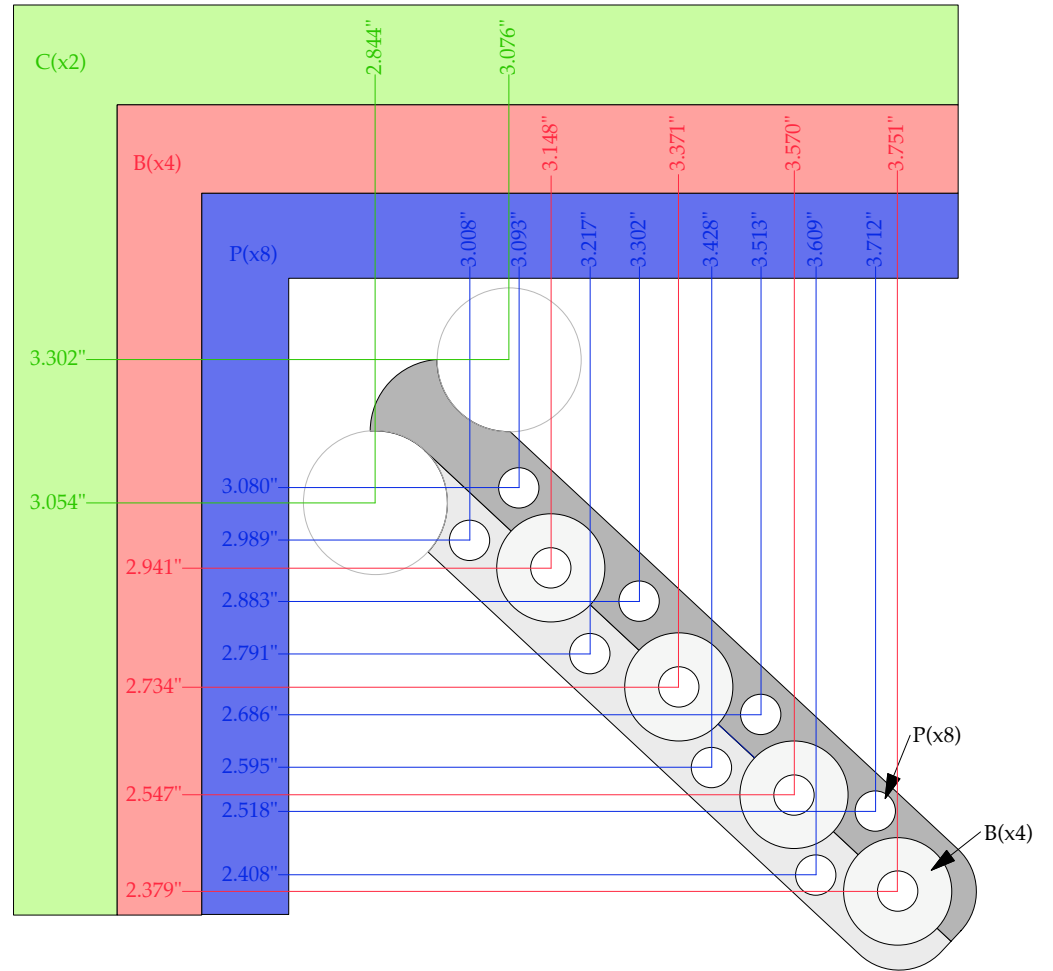

(Dimensions measured from lower left hand corner of cavity body)

UNIBODY LITTRAW LASER -- SELECTED DETAIL

E. COOK, P. MARTIN, D. STECK

2/24/10

TOP VIEW

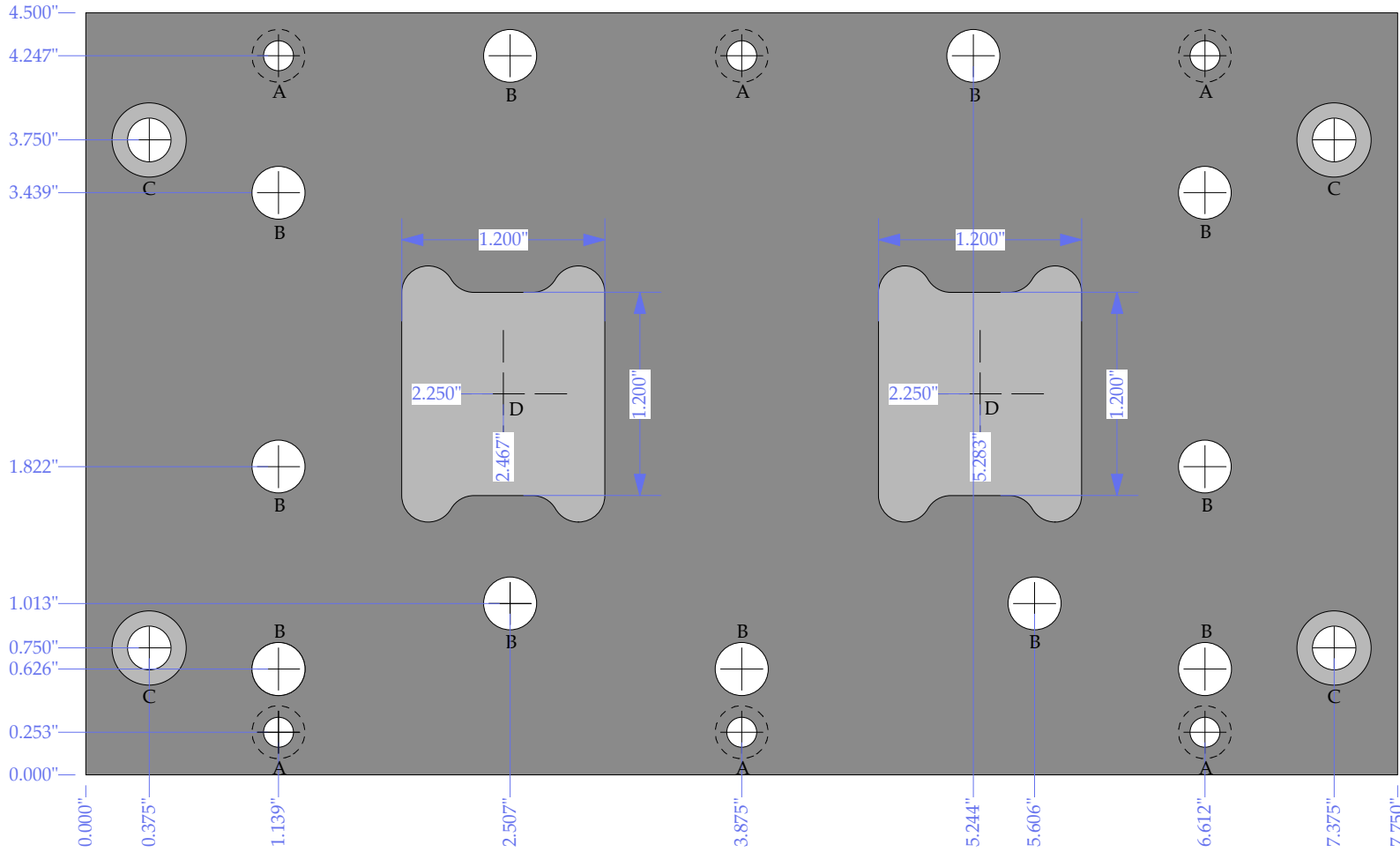

NOTES:

- A: 8-32 clearance ($\text{\O} 0.177''$) through part with $\text{\O} 0.313''$ counterbore, 0.164" deep from bottom; for mounting lower lid to baseplate.
- B: $\text{\O} 0.313''$ through part (to clear screws which attach the lower lid to the main cavity).
- C: 1/4-20 clearance ($\text{\O} 0.257''$) through part with $\text{\O} 0.438''$ counterbore, 0.250" deep.
- D: 1.200" x 1.200" square hole (with 5/16" circles on corners to allow for machining); cut 0.020" deep and centered as shown. Bottom of channel should be a very flat surface (set finishing pass to minimize machining marks and tool chatter).

ADDITIONAL NOTES:

1. Material is 6061-T6 aluminum. Starting block is 4.5" x 7.75" x 1".
2. Standard tolerance is 0.005" unless otherwise noted.

FRONT VIEW

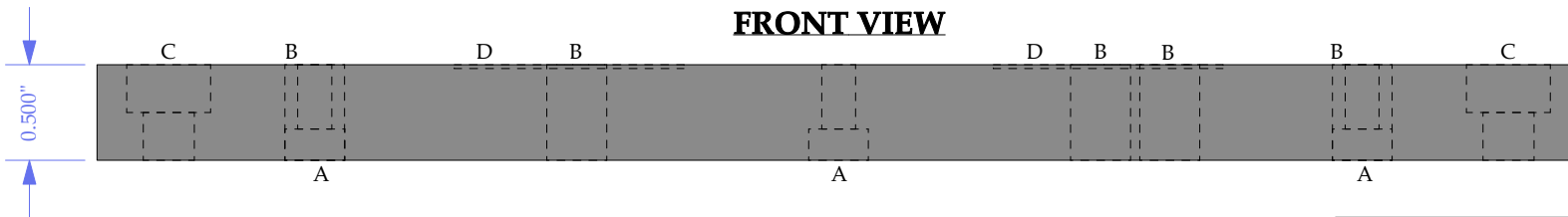

UNIBODY LITROW LASER -- BASEPLATE

E. COOK, P. MARTIN, D. STECK

2/24/10

TOP VIEW

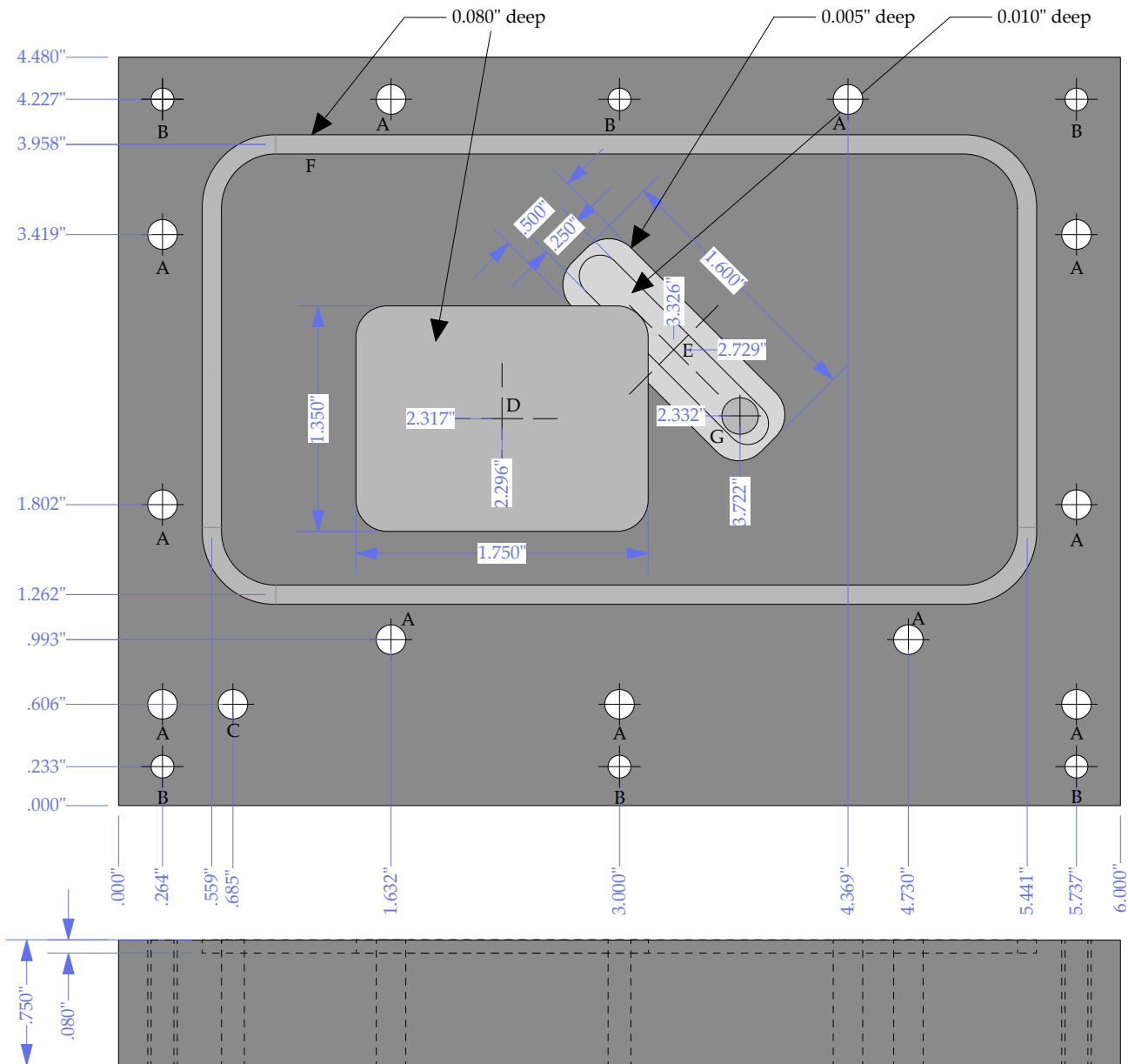

FRONT VIEW

NOTES:

- A: 8-32 clearance through part ($\text{Ø} 0.177$ "), for mounting lids to main cavity.
- B: 8-32 tapped through part, for mounting lower lid to baseplate.
- C: $\text{Ø} 0.177$ " hole through part.
- D: $1.750 \times 1.350 \times 0.080$ " deep rectangular hole with $\text{Ø} 3/8$ " fillets, and centered as shown. Dimensions not critical.
- E: $1.600 \times 0.500 \times 0.005$ " deep rectangular hole with $\text{Ø} 3/8$ " fillets, inset with a $1.500 \times 0.250 \times 0.010$ " deep rectangular hole with $\text{Ø} 1/4$ " fillets, rotated 45° relative to rest of part, and centered as shown. Dimensions not critical. (Inset border to be used to align grating arm.)
- F: 0.115 " wide flat-bottom channel, 0.080 " deep, oriented as shown. Channel is for a $3/32$ " thick, 4.5 " inner diameter O-ring.
- G: $\text{Ø} 7/32$ " flat-bottom hole, 0.055 " deep, for a $1/16$ " thick, $5/64$ " inner diameter O-ring.

ADDITIONAL NOTES:

1. Material is 6061-T6 aluminum. Starting block is $4.48 \times 6 \times 0.75$ ".
2. Standard tolerance is 0.005 " unless otherwise noted.

UNIBODY LITTROW LASER -- CAVITY LIDS

E. COOK, P. MARTIN, D. STECK

2/24/10

TOP VIEW

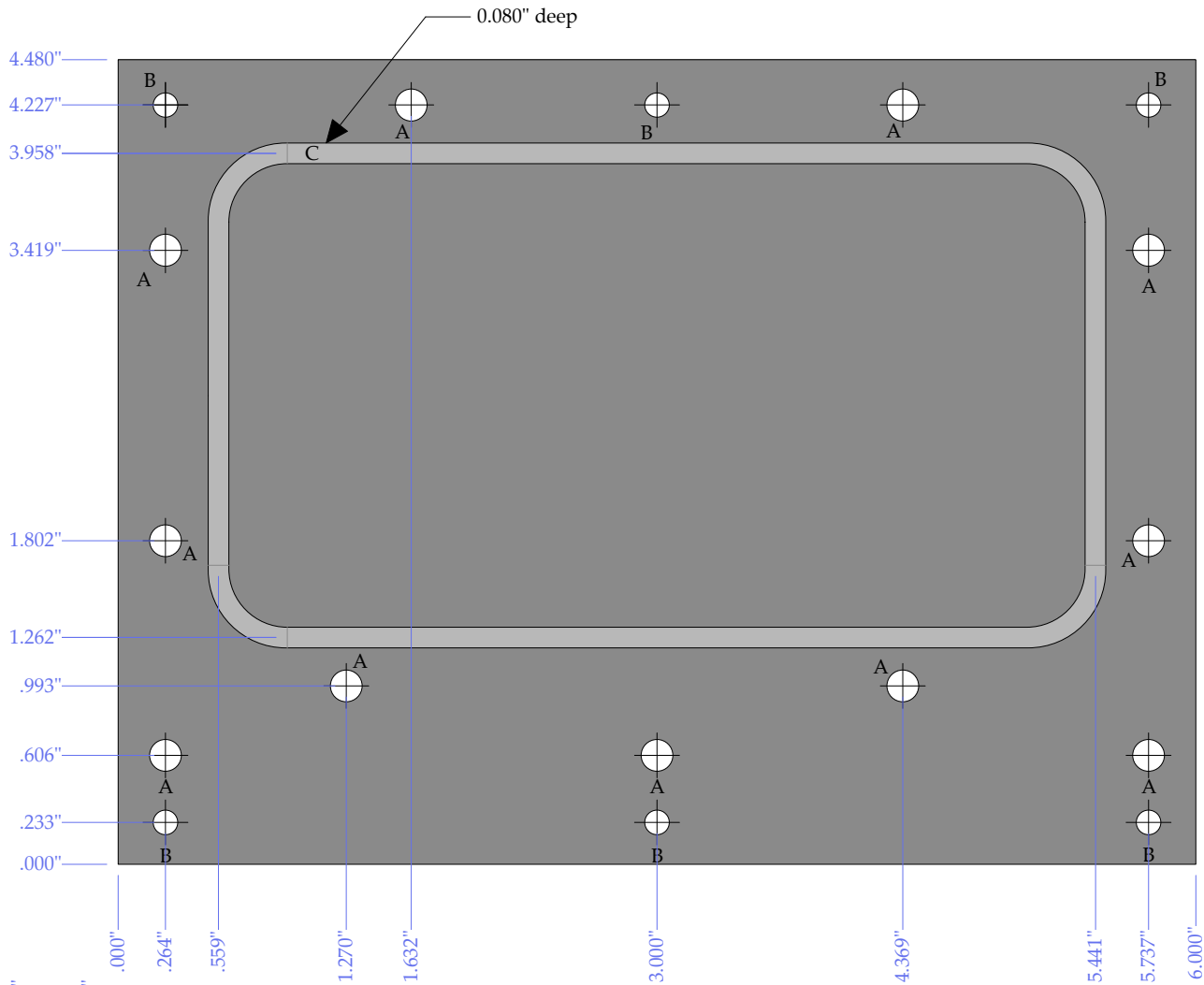

FRONT VIEW

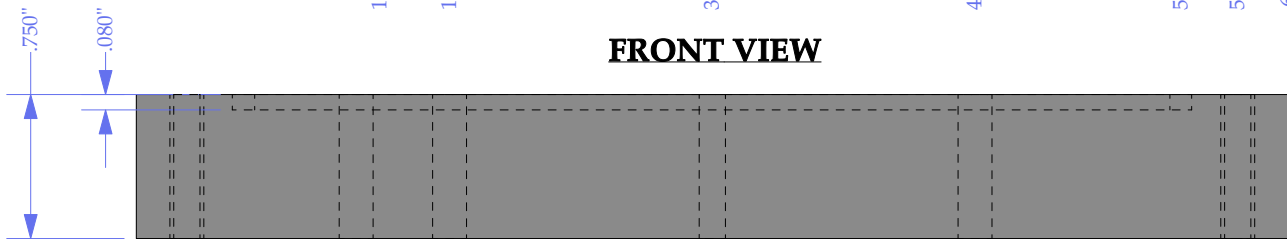

NOTES:

- A: 8-32 clearance through part (\varnothing 0.177"), for mounting lids to main cavity.
- B: 8-32 tapped through part.
- C: 0.115" wide flat-bottom channel, 0.080" deep, oriented as shown. Channel is for a 3/32" thick, 4.5" inner diameter O-ring.

ADDITIONAL NOTES:

1. Material is 6061-T6 aluminum. Starting block is 4.48" x 6" x 0.75".
2. Standard tolerance is 0.005" unless otherwise noted.

UNIBODY LITTROW LASER -- NEW TOP LID

E. COOK, P. MARTIN, D. STECK

2/24/10

UNIBODY LITTROW LASER -- ISOLATOR ADAPTER II

E. COOK, P. MARTIN, D. STECK

09/24/10

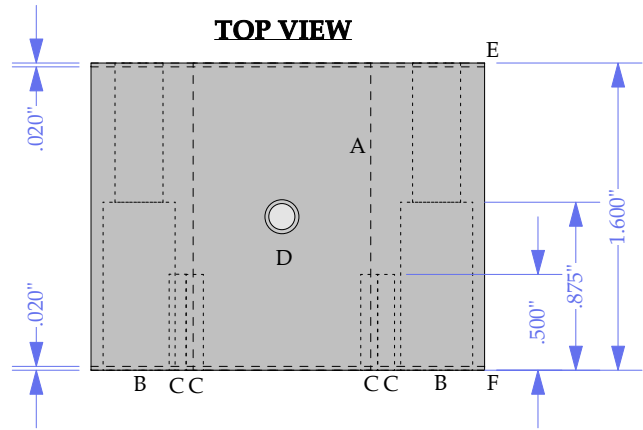

FRONT VIEW

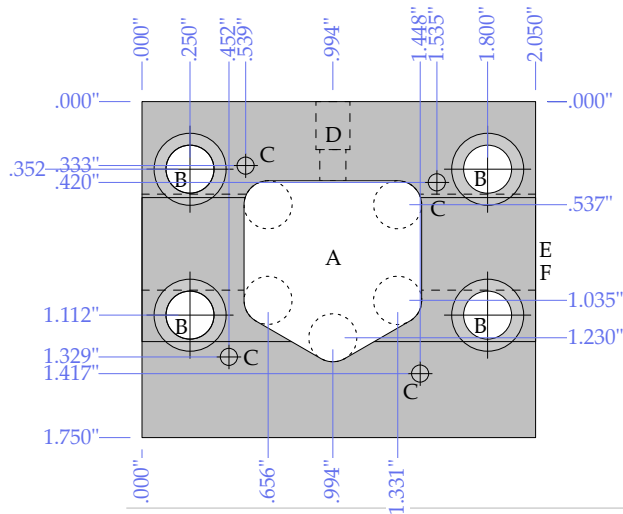

SIDE VIEW

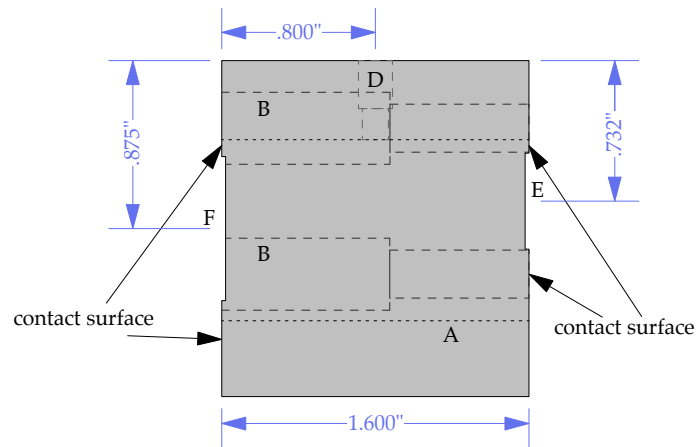

ASSEMBLY

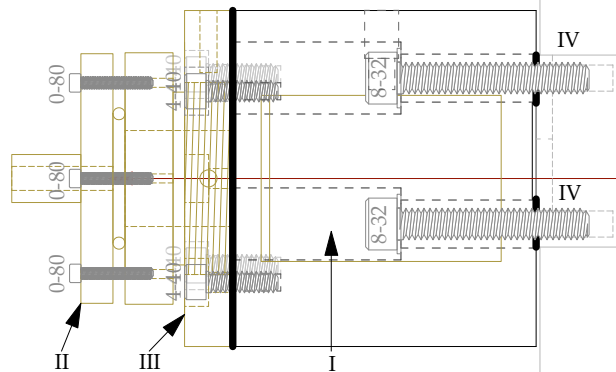
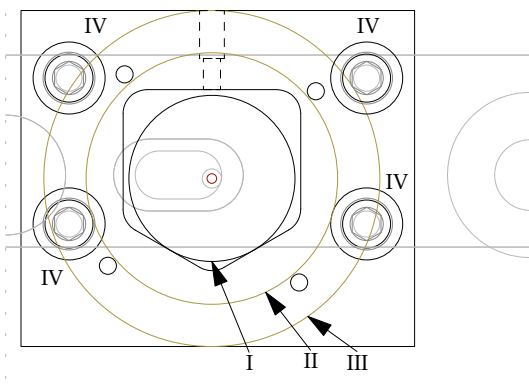

NOTES:

- A. Cavity thru piece, corner fillets \varnothing 0.250"
- B. 8-32 clearance, extra loose fit (\varnothing 0.250"), with loose counterbore \varnothing 0.375", 0.875" deep (screw requires a 0.310" outer diameter washer for assembly). (x4)
- C. 4-40 tapped 0.5" deep (x4, located on square side length 1" rotated 5 deg clockwise). Holes not included in side view for clarity.
- D. 8-32 clearance, free fit, to 0.250" deep, then 8-32 tapped through to cavity A.
- E. 0.500" wide relief cut, 0.020" deep. On back of part and centered as shown.
- F. 0.750" wide relief cut, 0.020" deep. On front of part and centered as shown.

PERIPHERALS:

- I. OFR body type II isolator, Thorlabs P/N IO-3D-(wavelength)-VLP
- II. Fiber coupler assembly: tilt plate with FC connectorized fiber port, Oz Optics
- III. Fiber coupler assembly to laser head adapter Oz Optics adapter #15.
- IV. 8-32 x 1" ss socket-head cap screw, w/ narrow profile (\varnothing 0.310" OD) washer.

ADDITIONAL NOTES:

1. Material is 6061-T6 aluminum. Starting block is 1.75" x 2.05" x 1.60".
2. Standard tolerance is 0.005" unless otherwise noted.
3. Surfaces marked "contact surface" must be made very flat (finishing pass with end mill, as little chatter as possible, lapped).

TOP VIEW

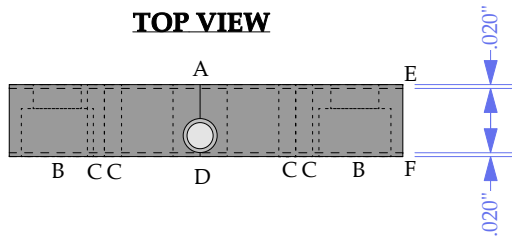

FRONT VIEW

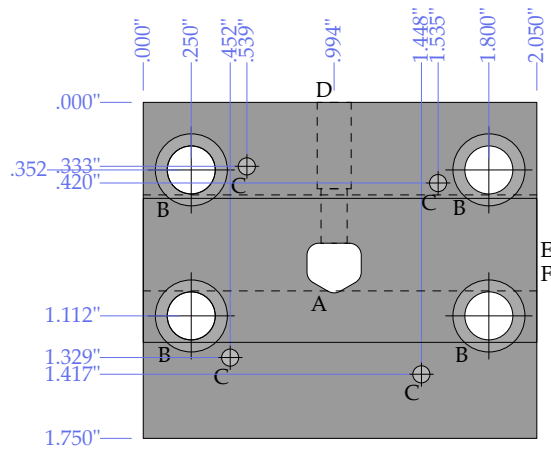

SIDE VIEW

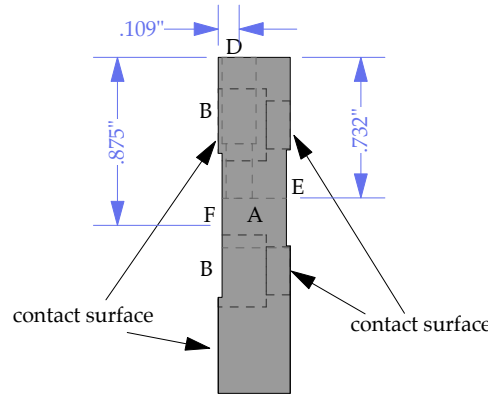

ASSEMBLY

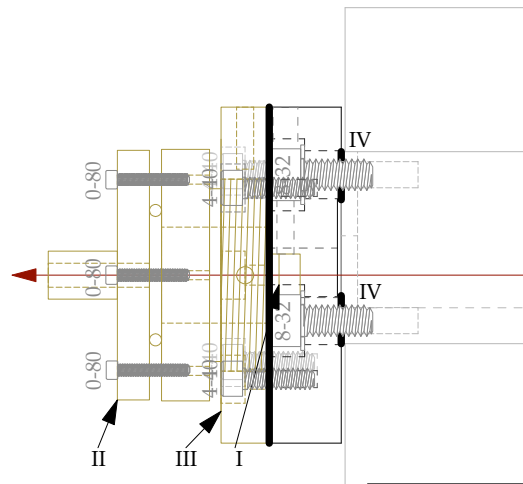
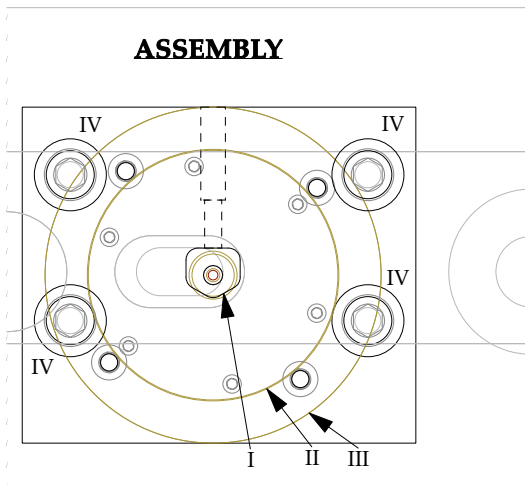

NOTES:

- A. Cavity thru piece, corner fillets $\text{\O} 0.125$ "
- B. 8-32 clearance, extra loose fit ($\text{\O} 0.250$ "), with loose counterbore $\text{\O} 0.375$ " , 0.250" deep (screw requires a 0.310" outer diameter washer for assembly). (x4)
- C. 4-40 tapped through part (x4, located on square side length 1" rotated 5 deg clockwise). Holes not included in side view for clarity.
- D. 8-32 clearance, free fit, to 0.450" deep, then 8-32 tapped through to cavity A.
- E. 0.500" wide relief cut, 0.020" deep. On back of part and centered as shown.
- F. 0.750" wide relief cut, 0.020" deep. On front of part and centered as shown.

PERIPHERALS:

- I. OFR tablet optical isolator, Thorlabs P/N IO-D-780-VLP
- II. Fiber coupler assembly: tilt plate with FC connectorized fiber port, Oz Optics P/N
- III. Fiber coupler assembly to laser head adapter Oz Optics adapter #15.
- IV. 8-32 x 0.375" ss socket-head cap screw, w/ narrow profile ($\text{\O} 0.310$ " OD) washer.

ADDITIONAL NOTES:

- 1. Material is 6061-T6 aluminum. Starting block is 1.75" x 2.05" x .375".
- 2. Standard tolerance is 0.005" unless otherwise noted.
- 3. Surfaces marked "contact surface" must be made very flat (finishing pass with end mill, as little chatter as possible, lapped).

UNIBODY LITTROW LASER -- CAVITY-COUPLER ADAPTER I

TOP VIEW

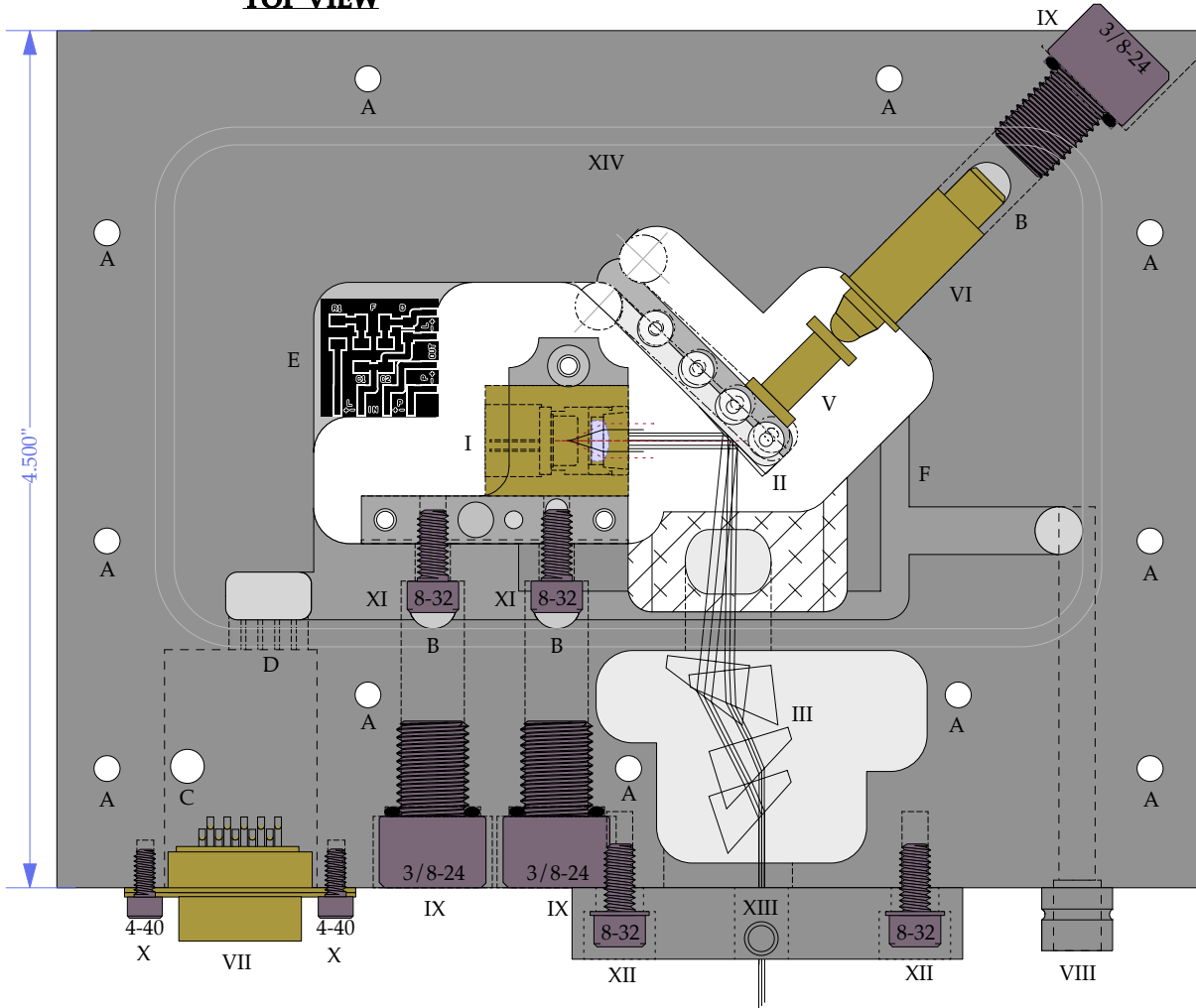

FRONT VIEW

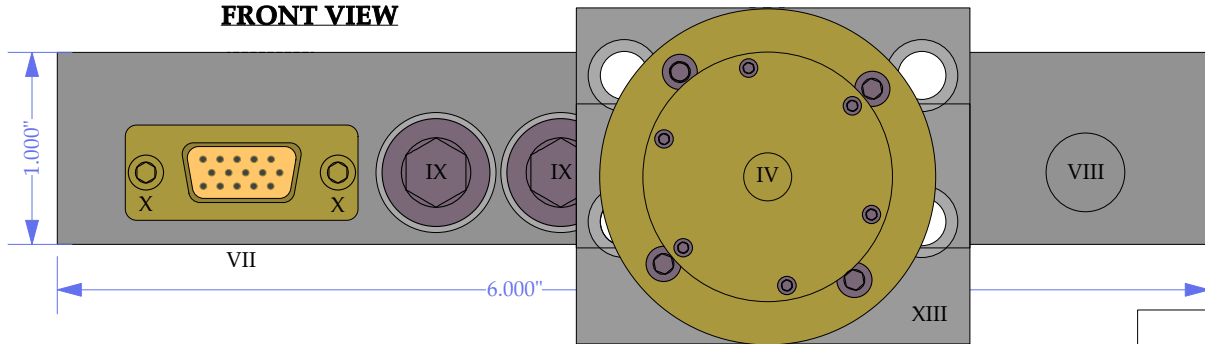

NOTES:

- A: 8-32 tapped holes for mounting lids.
- B: $\text{Ø } 1/4$ " holes for venting screws.
- C: $\text{Ø } 0.177$ " hole to pass TEC current wires to underside of main cavity.
- D: Five $\text{Ø } 0.063$ " holes to function as wire feedthroughs.
- E: Shelf for laser-head protection circuit board.
- F: $1/8$ " deep venting channel, which also functions to run wires to the piezo and temperature sensors.

PERIPHERALS:

- I: Diode collimation tube with optic; Thorlabs P/N LT230P-B.
- II: Holographic diffraction grating, lines/mm determined by desired wavelength. Custom size (12mm x 6mm x 3mm) available through Newport.
- III: AR coated anamorphic prism pair; Thorlabs P/N PS871-B.
- IV: Oz Optics pigtailed PM fiber coupler (with hardware).
- V: Low-voltage stacked Piezoelectric actuator from Noliac; P/N SCMA (5 mm x 5 mm x 10 mm; 60 V max voltage; 1000 N blocking force).
- VI: $1/4$ -100 fine adjustment screw, sleeve diameter $\text{Ø } 0.343 \pm 0.001$ "; New Focus P/N 9376-K. Cut hole $\text{Ø } 0.345 \pm 0.001$ " for tight fit.
- VII: D-sub 15 contact female connector, shell size E.
- VIII: Built-in $1/4$ " vacuum seal-off valve (see Cryocomp P/N V1021-1) to be used with a valve operator (Crycomp P/N V1025-3).
- IX: $3/8$ -24 x 0.5" stainless steel socket-head cap screw, with $3/8$ " ID $1/16$ " thick Viton O-ring.
- X: 4-40 x 0.25" stainless steel socket-head cap screw.
- XI: 8-32 x 0.375" stainless steel socket-head cap screw.
- XII: 8-32 x 0.375" stainless steel socket-head cap screw, with narrow profile ($\text{Ø } 0.310$ " OD) washer.
- XIII: Optical isolator adapter plate (see additional drawings).
- XIV: Viton O-ring, 4-1/2" ID $3/32$ " thick, McMaster P/N 1201T827. Inserted in grooves on lids.

UNIBODY LITROW LASER -- ASSEMBLY DRAWING

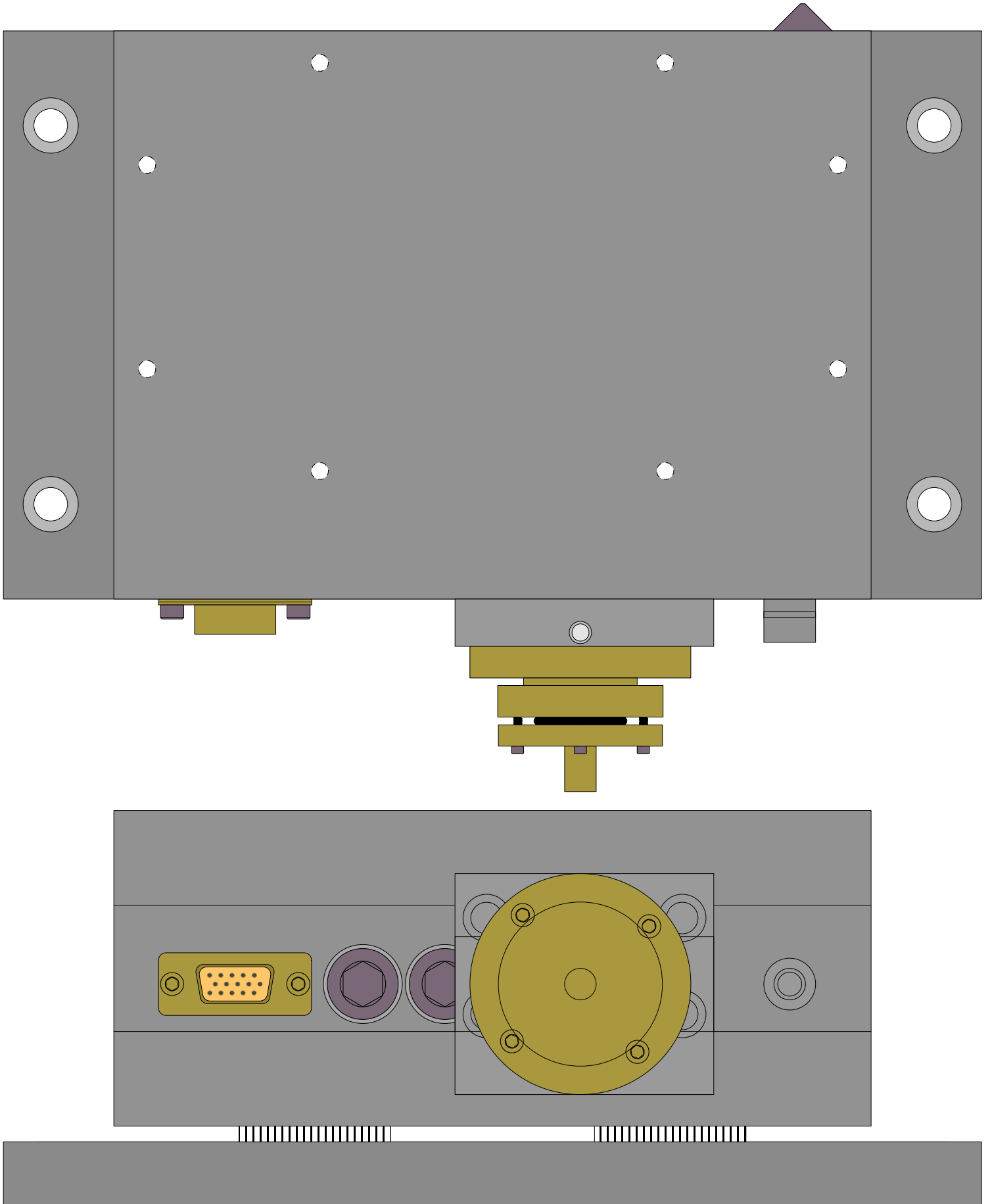

UNIBODY LITTROW LASER -- FULL ASSEMBLY DRAWING

E. COOK, P. MARTIN, D. STECK

3/24/11